

Wall to Floor Safety  
Rails with Outrigger  
1.25" dia. (32mm) or 1.50" dia. (38mm)  
**with Exposed Flanges**  
Architectural, Commercial, Institutional

### Raised 3 Hole Exposed Flange

**SPECIFICATION: (Stainless Steel)**

Wall to Floor Safety Rail with Outrigger and raised 3 hole exposed flanges. Manufactured by ELCOMA from 18 gauge, type 304, satin finished, stainless steel tubing. 14 gauge stainless steel mounting flange shall be Heliarc welded to the tube to form a single structural unit. Rail shall comply with all applicable federal and local building and safety codes.

1.25" (32 mm) rail dia.  
1.50" (38 mm) rail dia.

Model # 15-223330SE with  
Model # 15-523330SE

(Substitute S for smooth)

For opposite orientation substitute # 16

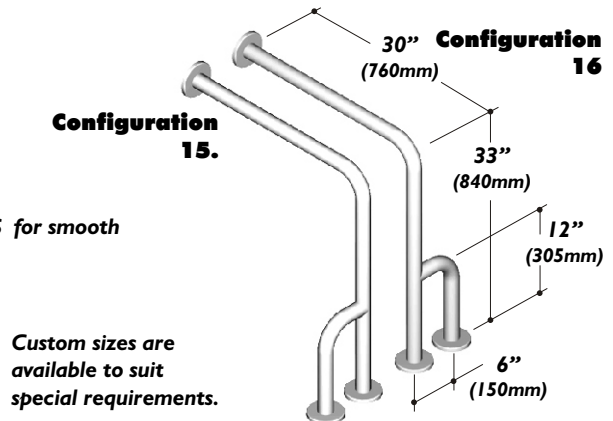

**SPECIFICATION: (Chrome Plated Steel)**

Wall to Floor Safety Rail with Outrigger and raised 3 hole exposed flanges. Manufactured by ELCOMA from 18 gauge steel tubing. 14 gauge steel mounting flange shall be brazed to the tube to form a single structural unit prior to triple plating. Rail shall comply with all applicable federal and local building and safety codes.

1.25" (32 mm) rail dia.  
1.50" (38 mm) rail dia.

Model # 15-213330SE (substitute S for smooth with K for Knurled grip)  
Model # 15-513330SE

For opposite orientation substitute # 16

### Raised 3 Hole "E" Exposed Flange



### Flat 2 hole Exposed Flange

**SPECIFICATION: (Stainless Steel)**

Wall to Floor Safety Rail with Outrigger and Flat 2 hole exposed flange. Manufactured by ELCOMA from 18 gauge, Type 304, satin finished, stainless steel tubing. 12 gauge stainless steel mounting flange shall be Heliarc welded to the tube to form a single structural unit. Rail shall comply with all applicable federal and local building and safety codes.

1.25" (32 mm) rail dia.  
1.50" (38 mm) rail dia.

Model # 15-223330SF (substitute S for smooth with K for Knurled grip,  
Model # 15-523330SF P for Peened grip, or G for SHUR-GRIP

### Flat 2 Hole "F" Exposed Flange



For painted bars there are more than 25 designer colors available on special request.  
All bars supplied with stainless steel mounting screws

