



Flip-up Safety Rail with Open Loop & "Friction Hinge"

KEY BENEFITS:

Safe and easy use by the handicapped.

The Friction Hinge Flip Up can be easily raised and lowered from a wheelchair with just a push. It doesn't need to be locked into position, the friction hinge holds the bar. It can't fall.

Designed to code

The open loop design allows a horizontal bar to pass under at 90° to meet specific code requirements.

Optional toilet paper holder available as a removable (shown) or fix item.

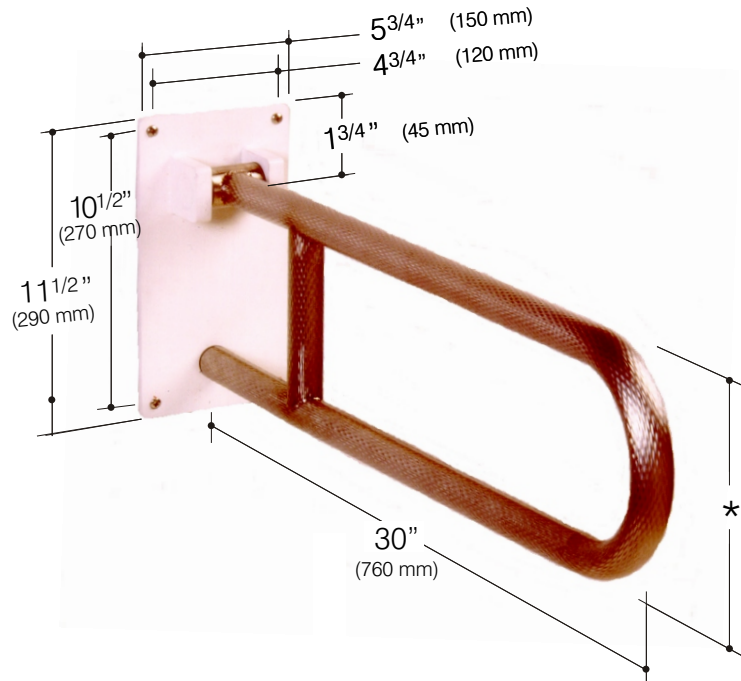

FEATURES:

The ELCOMA "Friction Hinge" flip-up moves smoothly and stops securely in either the vertical or horizontal position.

Alloy and stainless steel construction. The hinge bracket is made from heavy duty die cast alloy. The bracket and 30" (760 mm) stainless steel bar are available with a brushed metal finish or painted in White or Almond. Custom lengths are available to suit special requirements.

ELCOMA offers choice in material, finish, grip and colour. The bars can be made of 18 gauge, Type 304 stainless steel or 18 ga. mild steel for chrome plated or painted finish. Available in 1.25" (32 mm) dia. Grip options include Smooth, Peened, Knurled or patterned SHUR-GRIP. Bars can be satin finished s.s., painted s.s., Satin or painted SHUR-GRIP s.s. or mild steel with chrome plated or painted finish.

More than 25 designer colors are available on special request.

Designed and tested to withstand more than 250lbs (113kg) used for verticle assistance in the down position.

Installation should be completed by a Qualified tradesman to assure that the unit will support the load for which it is intended.

Product, supported by a Lifetime Warranty against defects in workmanship

* 8" (200 mm) for
1 1/4" dia. bar

* 9 3/4" (250 mm) for
1 1/2" dia. bar



Flip-up Safety Rail with Open Loop & "Friction Hinge"

SPECIFICATIONS

SPECIFICATION: (Stainless Steel)

Flip Up safety rail with friction hinge and open loop, manufactured by ELCOMA. Rail shall be 18 gauge Type 304 stainless steel tubing with brushed satin finish*. Hinge bracket shall be heavy duty die cast alloy with brushed satin finish*.

- *For Stainless Steel rail & Satin finish bracket Model # 99-2230SW05 (substitute S for Smooth with K for Knurled grip
- *For White painted rail & bracket Model # 99-2630S01 or P for Peened grip, or G for Shur-grip)
- * For Almond painted rail & bracket Model # 99-2630S02

* For a bracket with a different finish than the rail, add detail W in front of color:
W05 for satin finish, W01 for white bracket, W02 for Almond bracket.
Eg: Stainless Steel Rail with White Bracket: Model # 99-2230SW01

SPECIFICATION: (Stainless Steel "SHUR-GRIP")

Flip Up safety rail with friction hinge and open loop, manufactured by ELCOMA. Rail shall be 18 gauge, Type 304 stainless steel tubing with patterned "SHUR-GRIP" brushed satin finish*. Hinge bracket shall be heavy duty die cast alloy with brushed satin finish*.

- * For Stainless steel rail & satin finish bracket Model # 99-2230GW05
- * For White painted rail & bracket Model # 99-2630G01
- * For Almond painted rail & bracket Model # 99-5630G02

* For a bracket with a different finish than the rail, add detail W in front of color:
W05 for satin finish, W01 for white bracket, W02 for Almond bracket.

SPECIFICATION: (Painted Steel)

Flip Up safety rail with friction hinge and open loop, manufactured by ELCOMA. Rail shall be 18 gauge steel tubing*. Hinge bracket shall be heavy duty die cast alloy with brushed satin-metallic finish*.

- * For White painted rail & bracket Model # 99-2530S01
- * For Almond painted rail & bracket Model # 99-2530S02

* For a bracket with a different finish than the rail, add detail W in front on color:
W05 for satin finish, W01 for white bracket, W02 for Almond bracket.

ACCESSORIES

*Optional toilet paper holder,
available as a removable
(shown) or fixed item.*

SPECIFICATION: (Toilet paper holder)

Toilet paper dispenser for Flip-up safety rail,
manufactured by ELCOMA from type 304 stainless steel.

- Removable with S.S. finish Model# 99-T
- Removable White or Almond Model# 99-T-01 or 99-T-02
- Fixed (to match bar) add /T Model# 99-2230S/TF

