

Folding Shower Seats

with Phenolic Surface

Architectural, Commercial,
Institutional, Residential

PHENOLIC SEAT

SPECIFICATION:

Folding shower seat manufactured by ELCOMA from 1" (25mm) diameter, 18 gauge and 1 1/4" (32mm) X 1 1/4" (32mm), 16 gauge, type 304 stainless steel tubing with #4 satin finish. Two wall mount brackets shall be 12 gauge type 304 stainless steel. The third support bracket shall be 18 gauge type 304 stainless steel. Solid Phenolic seat slats shall be 1/2" (13mm) thick and 4 7/16" (111mm) wide and shall be fire and mildew resistant. Seat unit shall comply with all applicable federal provincial and local building and safety codes.

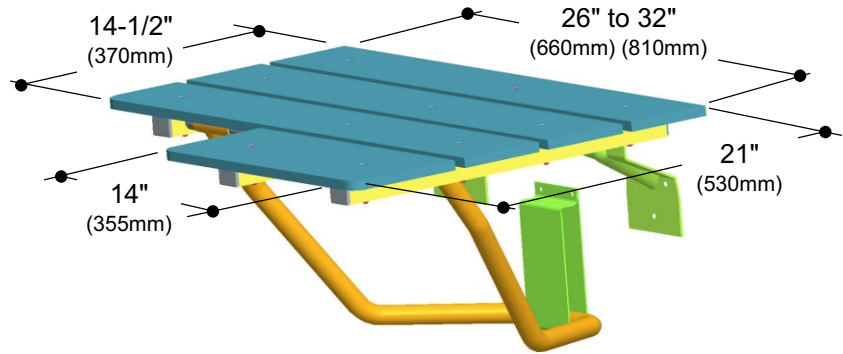

Configuration #61 Shown

Custom sizes are available to suit special requirements.

| | | | |
|-------------------------------|-----------|-------------------|------------|
| 26" X 21" (660 X 530 mm) seat | White | Model # 61-PH2601 | (As Shown) |
| 26" X 21" (660 X 530 mm) seat | Woodgrain | Model # 61-PH2615 | (As Shown) |
| 28" X 21" (710 X 530 mm) seat | White | Model # 61-PH2801 | (As Shown) |
| 28" X 21" (710 X 530 mm) seat | Woodgrain | Model # 61-PH2815 | (As Shown) |
| 30" X 21" (760 X 530 mm) seat | White | Model # 61-PH3001 | (As Shown) |
| 30" X 21" (760 X 530 mm) seat | Woodgrain | Model # 61-PH3015 | (As Shown) |
| 32" X 21" (810 X 530 mm) seat | White | Model # 61-PH3201 | (As Shown) |
| 32" X 21" (810 X 530 mm) seat | Woodgrain | Model # 61-PH3215 | (As Shown) |

For opposite orientation substitute Model # 61 for Model # 60

The ELCOMA standard of product quality is supported by a **Lifetime Warranty** on all stainless components. Elcoma Shower Seats have been designed and tested to withstand 400lbs. (182kg) * of load capacity when properly installed. This exceeds HUD, FHA, VA, ADA, ANSI, and other federal, provincial, and local codes. *



Folding Shower Seats

with Phenolic Surface

Architectural, Commercial,
Institutional, Residential

PHENOLIC SEAT

SPECIFICATION:

Folding shower seat manufactured by ELCOMA from 1" (25mm) diameter, 18 gauge and 1 1/4" (32mm) X 1 1/4" (32mm), 16 gauge, type 304 stainless steel tubing with #4 satin finish. Two wall mount brackets shall be 12 gauge type 304 stainless steel. The third support bracket shall be 18 gauge type 304 stainless steel. Solid Phenolic seat slats shall be 1/2" (13mm) thick and 4 7/16" (111mm) wide and shall be fire and mildew resistant. Seat unit shall comply with all applicable Federal and local building and safety codes.

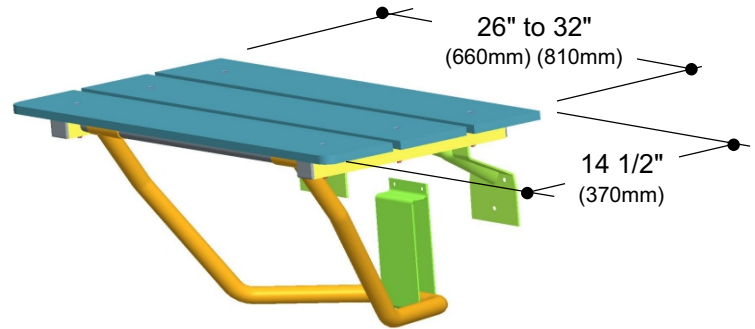

Configuration #62 Adult Folding Shower Seat Shown

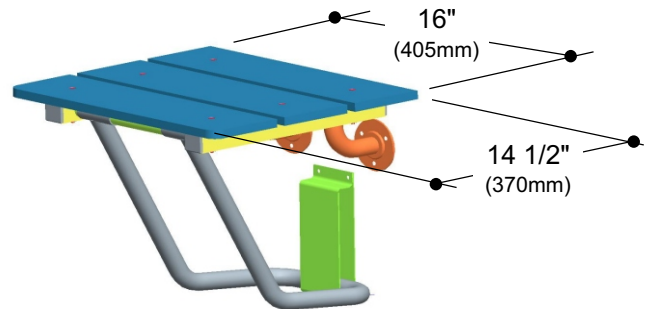

Configuration #63 Junior Folding Shower Seat Shown

Custom sizes are available to suit special requirements.

| | | | |
|-----------------------------------|-----------|-------------------|------------|
| 26" X 14 1/2" (660 X 370 mm) seat | White | Model # 62-PH2601 | (As Shown) |
| 26" X 14 1/2" (660 X 370 mm) seat | Woodgrain | Model # 62-PH2615 | (As Shown) |
| 28" X 14 1/2" (710 X 370 mm) seat | White | Model # 62-PH2801 | (As Shown) |
| 28" X 14 1/2" (710 X 370 mm) seat | Woodgrain | Model # 62-PH2815 | (As Shown) |
| 30" X 14 1/2" (760 X 370 mm) seat | White | Model # 62-PH3001 | (As Shown) |
| 30" X 14 1/2" (760 X 370 mm) seat | Woodgrain | Model # 62-PH3015 | (As Shown) |
| 32" X 14 1/2" (810 X 370 mm) seat | White | Model # 62-PH3201 | (As Shown) |
| 32" X 14 1/2" (810 X 370 mm) seat | Woodgrain | Model # 62-PH3215 | (As Shown) |
| 16" X 14 1/2" (405 X 370 mm) seat | White | Model # 63-PH1601 | (As Shown) |
| 16" X 14 1/2" (405 X 370 mm) seat | Woodgrain | Model # 63-PH1615 | (As Shown) |

The ELCOMA standard of product quality is supported by a **Lifetime Warranty** on all stainless components. Elcoma Adult Shower Seats have been designed and tested to withstand 400lbs. (182kg) * of load capacity when properly installed. This exceeds HUD, FHA, VA, ADA, ANSI and other federal, and local codes. * The Junior Folding Shower Seat has been designed and tested to withstand 250lbs (114kg).

